

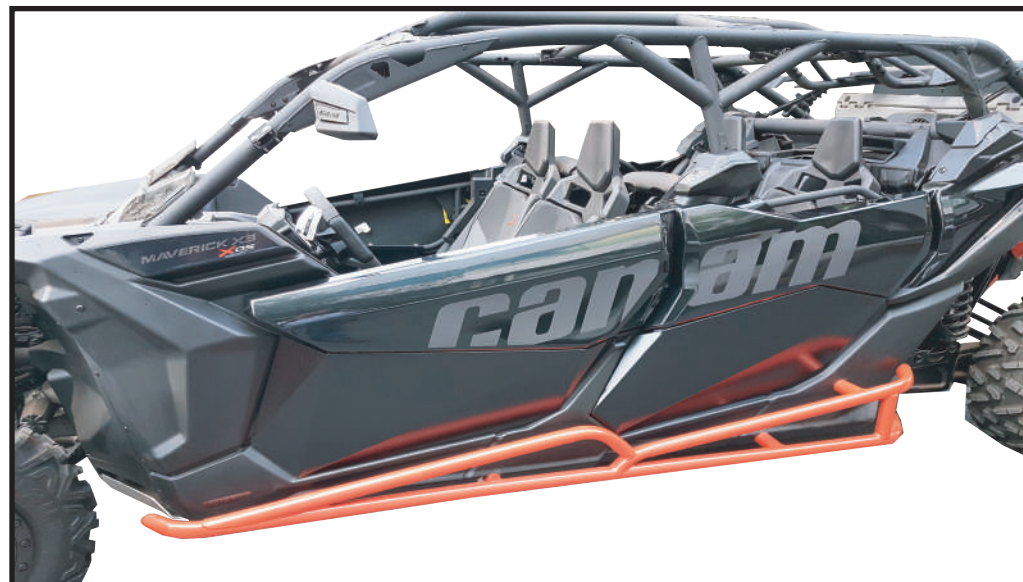

ALUMINUM LOWER DOORS INSTALLATION MANUAL



For technical support , please write us to:
info@afxmotorsports.com or call us at:
Ph. 956-242-6521

HAVE FUN AND A SAFE RIDE!



www.afxmotorsports.com

4610 Modern Lane, Laredo, TX 78041 Ph. 956-242-6521

CAN AM X3 Max 4 SEATER

SKU PUE030





ALUMINUM FRONT LOWER DOORS FOR CAN AM X3 4 SEATER

HOW TO MAKE THE INSTALLATION

Pieces included:

- Aluminum Lower Door, passengers side.

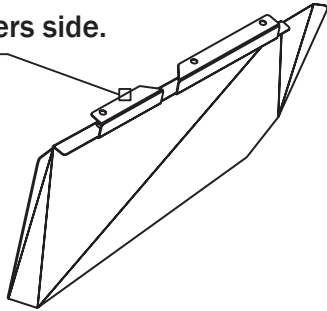

- Aluminum Lower Door, drivers side.

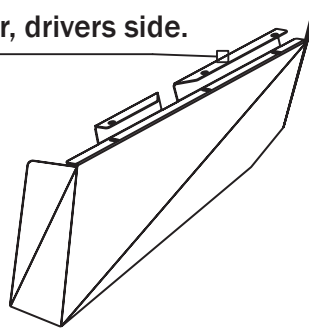

-  (6x) 1/4" x 2" Bolts with washers and nuts.

Tools needed (Not Included):

- 5/32" Allen Key
- 7/16" Combination Wrench.

Liability Statement

AFX Motorsports products are designed to best fit user's ATV/UTV under stock conditions. Adding, modifying, or fabricating any factory or aftermarket parts will void any warranty provided by AFX Motorsports and is not recommended. AFX Motorsports products could interfere with other aftermarket accessories. If user has aftermarket products on machine, contact AFX Motorsports to verify that they will work together. Although AFX Motorsports has thousands of satisfied customers, user should be aware that installing bumpers, rock sliders, spare tire carriers, etc. will change the ride of machine and may increase maintenance and part wear. Operating any off-road machine while, or after, consuming alcohol and/or drugs increases risk of bodily harm or death. No warranty or representation is made as to this product's ability to protect user from severe injury or death. AFX Motorsports urges operators and occupants to wear a helmet and appropriate riding gear at all times. By purchasing and installing AFX Motorsports products, user agrees that should damages occur, AFX Motorsports will not be held responsible for loss of time, use, labor fees, replacement parts, or freight charges. AFX Motorsports, nor any 3rd party, will not be held responsible for any direct, indirect, incidental, special, or consequential damages that result from any product purchased from AFX Motorsports. The total liability of seller to user for all damages, losses, and causes of action, if any, shall not exceed the total purchase price paid for the product that gave rise to the claim. AFX Motorsports will warranty only parts provided by AFX Motorsports. Any damage or problems with OEM housings, bearings, seals, or other manufacturers' products will not be covered by AFX Motorsports. AFX Motorsports parts and products are not warranted if item was not installed properly, misused, or modified.

1

Remove the lower original plastics from the vehicles doors. For this, uninstall the 2 screws from each door and remove the plastics.

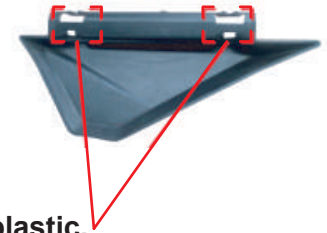

Remove the 2 screws of the plastic.

2

Set the Aluminum Lower Door (Driver's or Passenger's side) as shown on the Figure below. Install the door with 3 1/4" x 2" screws with 2 washers and 1 nut each (Included). Before tighten the screws, be sure that every one is in its right position.

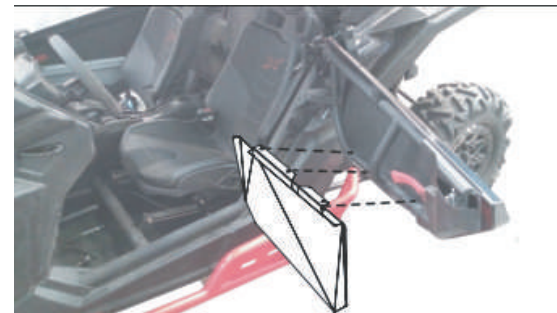

- 3** Next, set the lower door in order that it will be aligned with the upper door of the vehicle.



Check the door to be aligned.

- 4** Once aligned, tighten the screws to the top, so that the lower door will be adjusted as possible.

- 5** Repeat this steps for the Lower Door of the other side of the Vehicle.

- 7** Finally tighten the 1/4 x 2" (D) screw (Make some pressure on the door in order to line the holes from the door with the holes on the structure of the upper door) use the washers and nuts.



- 8** Tighten all the bolts and place the plastic guard over the handle and adjust using the 3x6mm hexagonal screws.



- 9** Repeat step 1 to 7 for the passenger side rear door.

5

Adjust and hand tighten the (B) screw (1/4 x 2"), use washers and nuts.

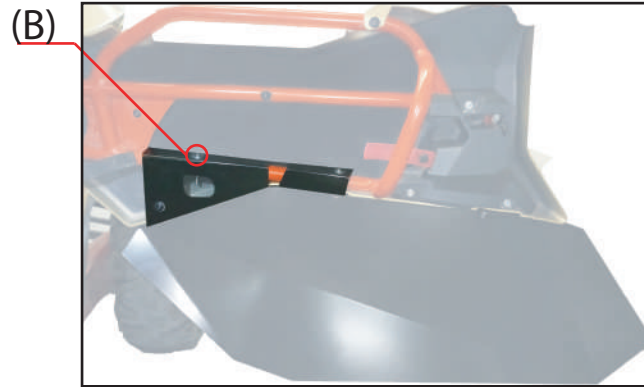

6

Adjust and hand tighten the (C) screws (1/4 x 2"), use washers and nuts.

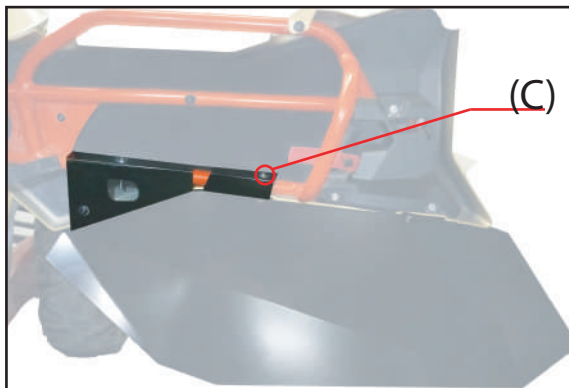

ALUMINUM REAR LOWER DOORS FOR CAN AM X3 4 SEATER

HOW TO MAKE THE INSTALLATION

Pieces included:

■ Aluminum Lower Door, Passengers Side.

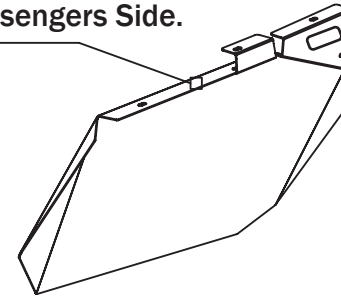

■ Aluminum Lower Door, Drivers Side.

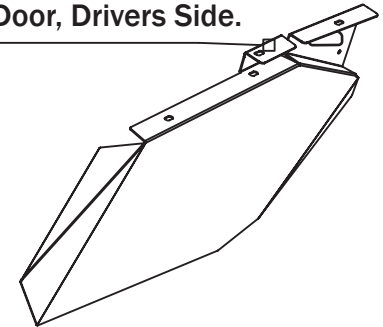

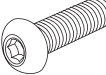
-  (6x) 1/4" x 2" Bolts with washers and nuts.
(6x) Hexagonal screw 6x30mm.

Tools needed (Not Included):

- 5/32" Allen Key
- 7/16" Combination Wrench.

1 Remove the original screw (A) from the inside of the upper door. (Keep the screw)

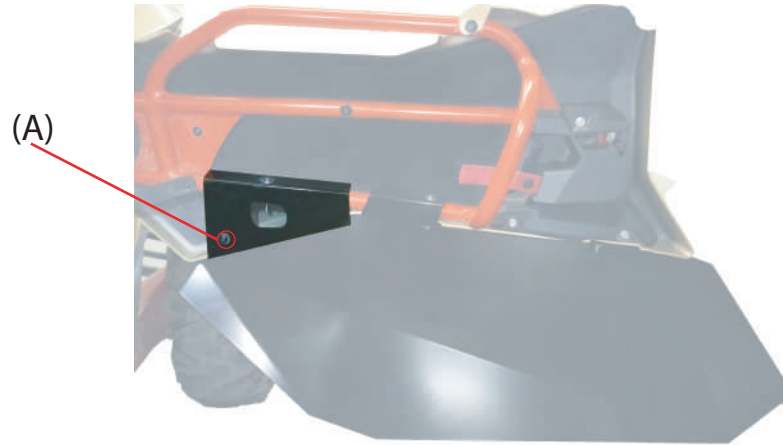

2 Remove the rivets from the handle guard on the inside of the door. Remove the handle guard and the plastic on the structure of the upper door.

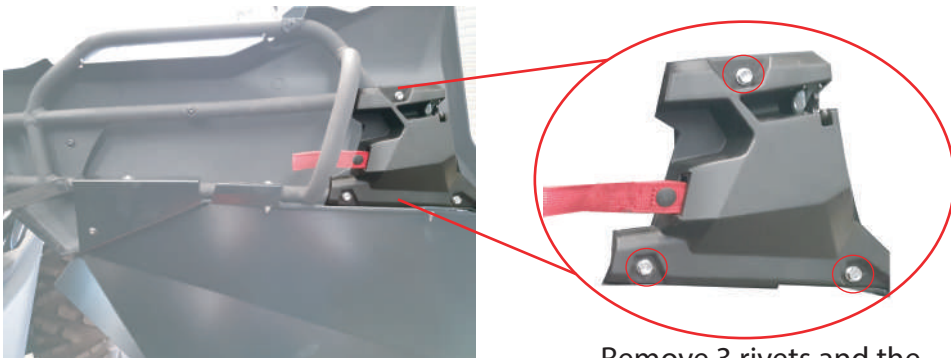

Remove 3 rivets and the plastic.

3 Line the half lower door with the original holes from the upper door structure (tube). Starting from A to D.

Note: In order to fit the lower door, you have to insert bolt "A" and push the door to get "B" inserted and so on to get "C" and "D". This is on purpose just to make the door turn into the position of fitting right in the lower part of the frame. All the holes of the rear door are designed this way.



4 Adjust and hand tighten the "A" screw (original screw).