



Application: '15-Current Polaris General Blow Hole Instructions

KIT CONTENTS:

- 1 – MTNTK Blow Hole w/ Silicone Adaptor
- 1 – Clamp

1. Lift rear bed exposing the engine.



2. Loosen the clamp on the clutch exhaust hose.

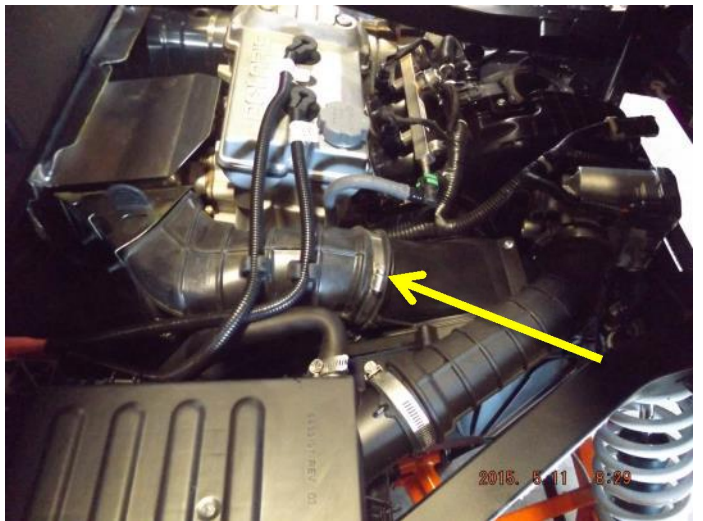

3. Separate the exhaust hose from the Clutch Housing.

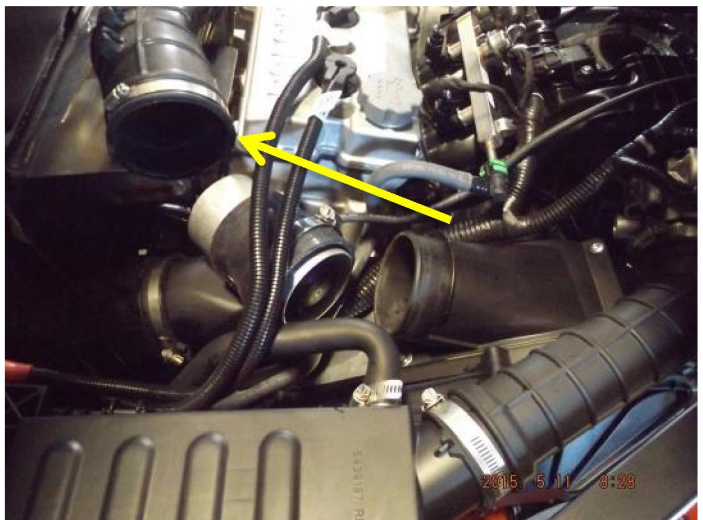

4. Now install Blow Hole onto Clutch housing as shown. Tighten clamp.



To Exhaust Hose

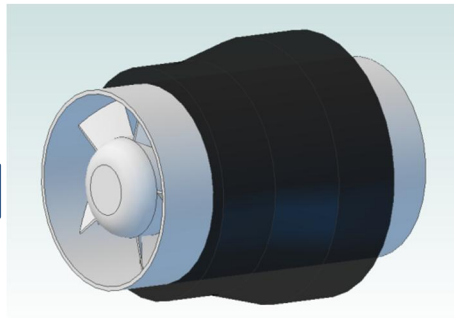
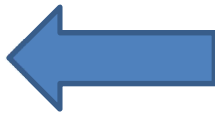

To Clutch Cover

5. Then install exhaust hose onto Blow Hole assembly. Tighten clamp.



6. Route wire along brake light power cable. Unplug tail light connector.



7. Plug in Blow Hole connector in line. The Blow Hole will run anytime the key is in the "On" position and for a brief 15 second time frame that the ECU keeps the chassis relay powered up after shutdown.



8. Check vent to ensure blow hole is forcing air out and not in.

ATTENTION:

We recommend you have a qualified service technician remove your clutch cover and inspect clutches/belt for any pre-existing problems. The Blow Hole cannot solve all belt/clutch heating problems, especially when a pre-existing condition due to worn or faulty parts is present. It is only used to aid in cooling clutches and belt.

For more information about installation, questions, or comments, please call MTNTK Performance at:

208-652-0122 OR EMAIL US AT ORDERS@MTNTKPERFORMANCE.COM